

COMPOSANTS A BRIDES A GRIFFES ISO K



Descriptif :

Destiné aux applications du vide, ce type de raccordement est composé d'éléments en Inox :

- Griffes de serrage
- Anneau de centrage
- Joint
- Bride à souder

Principe de fonctionnement :

Les brides sont raccordées par l'intermédiaire d'un anneau de centrage et d'un joint d'étanchéité. L'assemblage est maintenu par des boulons à griffes.

Performances :

- Etanchéité de haute qualité
- Pression : vide allant jusqu'à 10^{-7} mbar
- Température d'étuvage limité par l'utilisation de joint type Viton à 130°C.
- Ø Couramment utilisés : de 63 à 250 mm

Qualité :

Ces éléments à brides sont conformes à la norme "Pneurop" 6601/1981 et DIN 28403.

Etat de propreté : tous les éléments sont garantis en propreté et conditionnés dans des emballages plastiques.

Domaines d'utilisation :

- Technologie du vide
- Industrie chimique
- Nucléaire

COMPOSANTS ISO K BRIDES A GRIFFES

Boulon à griffe

VIKGS

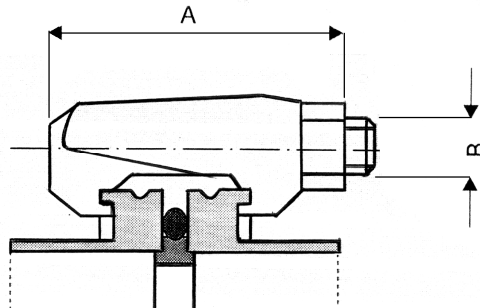

Ø nominal	A	B	C	Acier Zingué	Inox 316
DN 63	60	M10	4	VIKGS250AZ	VIKGS250I
DN 80	60	M10	4	VIKGS250AZ	VIKGS250I
DN 100	60	M10	4	VIKGS250AZ	VIKGS250I
DN 160	60	M10	6	VIKGS250AZ	VIKGS250I
DN 200	60	M10	6	VIKGS250AZ	VIKGS250I
DN 250	60	M10	6	VIKGS250AZ	VIKGS250I
DN 320	75	M12	8	VIKGS500AZ	VIKGS500I
DN 400	75	M12	8	VIKGS500AZ	VIKGS500I
DN 500	75	M12	12	VIKGS500AZ	VIKGS500I

C : Nombre de griffes minimum, code à l'unité

VERSION ALUMINIUM

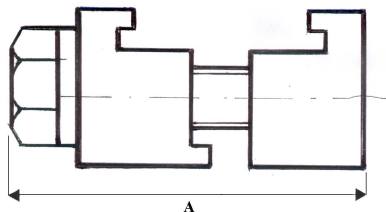

nominal	A	B	C	Référence
DN 63	45	M8	4	VIKGS100A
DN 80	45	M8	4	VIKGS100A
DN 100	45	M8	4	VIKGS100A
DN 160	45	M10	4	VIKGS250A
DN 200	45	M10	6	VIKGS250A
DN 250	45	M10	6	VIKGS250A

C : Nombre de griffes

Demi griffe

VIKDG

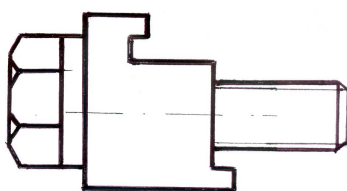

nominal	A	B	C	Aluminium	Inox
DN 63	23.5	M8	4	VIKDG100A	VIKDG100I
DN 80	23.5	M8	4	VIKDG100A	VIKDG100I
DN 100	23.5	M8	4	VIKDG100A	VIKDG100I
DN 160	23.5	M10	4	VIKDG250A	VIKDG250I
DN 200	23.5	M10	6	VIKDG250A	VIKDG250I
DN 250	23.5	M10	6	VIKDG250A	VIKDG250I

Anneau de centrage avec joint

VIKA

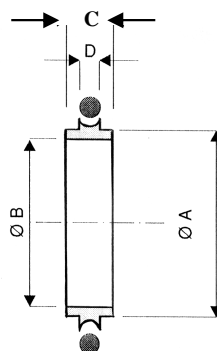

Ø nominal	A	B	C	D	Inox 316L/FKM	Inox 316L/EPDM	Inox 316L/NBR
DN 63	70	68	8	3.9	VIKA63ILV	VIKA63ILE	VIKA63ILN
DN 80	83	81	8	3.9	VIKA80ILV	VIKA80ILE	VIKA80ILN
DN 100	102	100	8	3.9	VIKA100ILV	VIKA100ILE	VIKA100ILN
DN 160	153	148	14	5.6	VIKA160ILV	VIKA160ILE	VIKA160ILN
DN 200	213	208	14	5.6	VIKA200ILV	VIKA200ILE	VIKA200ILN
DN 250	261	256	14	5.6	VIKA250ILV	VIKA250ILE	VIKA250ILN
Ø nominal	A	B	C	D	Inox 304/FKM	Inox 304/EPDM	Inox 304/NBR
DN 63	70	68	8	3.9	VIKA63IV	VIKA63IE	VIKA63IN
DN 80	83	81	8	3.9	VIKA80IV	VIKA80IE	VIKA80IN
DN 100	102	100	8	3.9	VIKA100IV	VIKA100IE	VIKA100IN
DN 160	153	148	14	5.6	VIKA160IV	VIKA160IE	VIKA160IN
DN 200	213	208	14	5.6	VIKA200IV	VIKA200IE	VIKA200IN
DN 250	261	256	14	5.6	VIKA250IV	VIKA250IE	VIKA250IN
DN 320					VIKA320IV	VIKA320IE	VIKA320IN
DN400					VIKA400IV	VIKA400IE	VIKA400IN
DN 500					VIKA500IV	VIKA500IE	VIKA500IN
Ø nominal	A	B	C	D	Aluminium/FKM	Aluminium/EPDM	Aluminium/NBR
DN 63	70	68	8	3.9	VIKA63AV	VIKA63AE	VIKA63AN
DN 80	83	81	8	3.9	VIKA80AV	VIKA80AE	VIKA80AN
DN 100	102	100	8	3.9	VIKA100AV	VIKA100AE	VIKA100AN
DN 160	153	148	14	5.6	VIKA160AV	VIKA160AE	VIKA160AN
DN 200	213	208	14	5.6	VIKA200AV	VIKA200AE	VIKA200AN
DN 250	261	256	14	5.6	VIKA250AV	VIKA250AE	VIKA250AN
DN 320					VIKA320AV	VIKA320AE	VIKA320AN
DN400					VIKA400AV	VIKA400AE	VIKA400AN
DN 500					VIKA500AV	VIKA500AE	VIKA500AN

Joint VIKJ

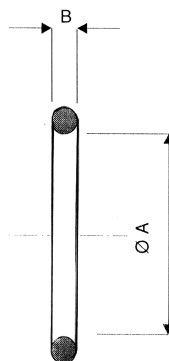

Ø nominal	A	B	FKM	EPDM	NBR
DN 63	75.6	5.3	VIKJ63V	VIKJ63E	VIKJ63N
DN 80	88.3	5.3	VIKJ80V	VIKJ80E	VIKJ80N
DN 100	107.3	5.3	VIKJ100V	VIKJ100E	VIKJ100N
DN 160	164.5	5.3	VIKJ160V	VIKJ160E	VIKJ160N
DN 200	215.3	5.3	VIKJ200V	VIKJ200E	VIKJ200N
DN 250	266.1	5.3	VIKJ250V	VIKJ250E	VIKJ250N
DN 320	330	7	VIKJ320V	VIKJ320E	VIKJ320N
DN 400	405	7	VIKJ400V	VIKJ400E	VIKJ400N
DN 500	507	7	VIKJ500V	VIKJ500E	VIKJ500N

Bride pleine à fixation par griffes VIKBP

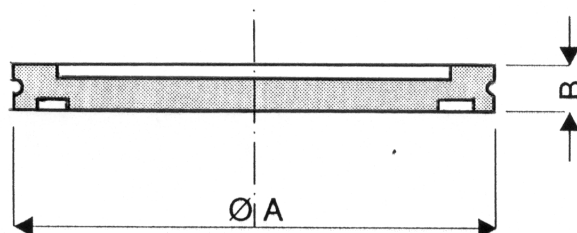

nominal	A	B	Inox 316L	Inox 304	Aluminium
DN 63	95	12	VIKBP63IL	VIKBP63I	VIKBP63A
DN 80	110	12	VIKBP80IL	VIKBP80I	VIKBP80A
DN 100	130	12	VIKBP100IL	VIKBP100I	VIKBP100A
DN 160	180	12	VIKBP160IL	VIKBP160I	VIKBP160A
DN 200	240	12	VIKBP200IL	VIKBP200I	VIKBP200A
DN 250	290	12	VIKBP250IL	VIKBP250I	VIKBP250A
DN 320	370	17	VIKBP320IL	VIKBP320I	VIKBP320A
DN 400	450	17	VIKBP400IL	VIKBP400I	VIKBP400A
DN 500	550	17	VIKBP500IL	VIKBP500I	VIKBP500A

Bride à souder fixation par griffes

VIKBBW ou BSW

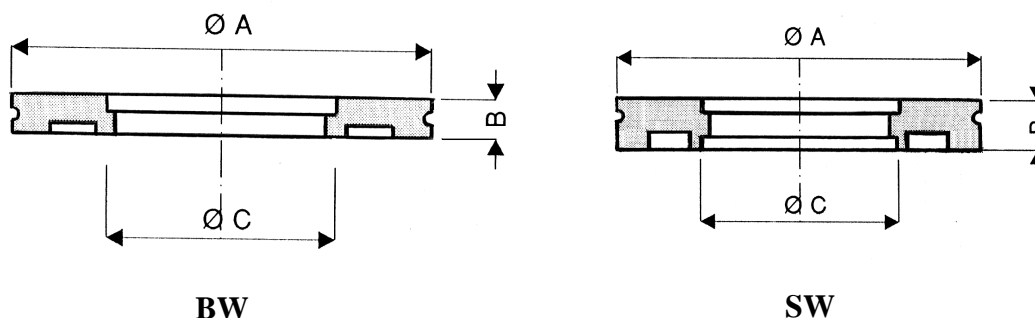

Ø nominal	A	B	C	Inox 316L BW	Inox 316L SW
DN 63	95	12	63.5	VIKBBW63IL40I	VIKBSW63IL40I
DN 63	95	12	76.1	VIKBBW64IL48I	VIKBSW64IL48I
DN 80	110	12	88.9	VIKBBW80IL48S	VIKBSW80IL48S
DN 100	130	12	101.6	VIKBBW100IL64I	VIKBSW100IL64I
DN 100	130	12	104	VIKBBW100IL104M	VIKBSW100IL104M
DN 100	130	12	114.3	VIKBBW100IL64S	VIKBSW100IL64S
DN 160	180	12	152.4	VIKBBW160IL96I	VIKBSW160IL96I
DN 160	180	12	154	VIKBBW160IL154M	VIKBSW160IL154M
DN 160	180	12	159	VIKBBW160IL159M	VIKBSW160IL159M
DN 160	180	12	168.3	VIKBBW160IL96S	VIKBSW160IL96S
DN 200	240	12	203.2	VIKBBW200IL128I	VIKBSW200IL128I
DN 200	240	12	219.1	VIKBBW200IL128S	VIKBSW200IL128S
DN 250	290	12	254	VIKBBW250IL160I	VIKBSW250IL160I
DN 250	290	12	267	VIKBBW250IL257M	VIKBSW250IL257M
DN 320	370	17	306	VIKBBW320IL306M	VIKBSW320IL306M
DN 400	450	17	406	VIKBBW400IL406M	VIKBSW400IL406M
DN 500	550	17	508	VIKBBW500IL508M	VIKBSW500IL508M

Ø nominal	A	B	C	Inox 304 BW	Inox 304 SW
DN 63	95	12	63.5	VIKBBW63I40I	VIKBSW63I40I
DN 63	95	12	76.1	VIKBBW64I48I	VIKBSW64I48I
DN 80	110	12	88.9	VIKBBW80I48S	VIKBSW80I48S
DN 100	130	12	101.6	VIKBBW100I64I	VIKBSW100I64I
DN 100	130	12	104	VIKBBW100I104M	VIKBSW100I104M
DN 100	130	12	114.3	VIKBBW100I64S	VIKBSW100I64S
DN 160	180	12	152.4	VIKBBW160I96I	VIKBSW160I96I
DN 160	180	12	154	VIKBBW160I154M	VIKBSW160I154M
DN 160	180	12	159	VIKBBW160I159M	VIKBSW160I159M
DN 160	180	12	168.3	VIKBBW160I96S	VIKBSW160I96S
DN 200	240	12	203.2	VIKBBW200I128I	VIKBSW200I128I
DN 200	240	12	219.1	VIKBBW200I128S	VIKBSW200I128S
DN 250	290	12	254	VIKBBW250I160I	VIKBSW250I160I
DN 250	290	12	267	VIKBBW250I257M	VIKBSW250I257M
DN 320	370	17	306	VIKBBW320I306M	VIKBSW320I306M
DN 400	450	17	406	VIKBBW400I406M	VIKBSW400I406M
DN 500	550	17	508	VIKBBW500I508M	VIKBSW500I508M

Bride tubulure à fixation par griffes

VIKBT

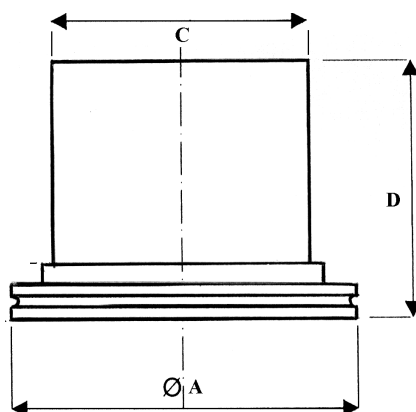

nominal	A	C	D	Inox 316L
DN 63	95	76.1	100	VIKBT63IL48I
DN 80	110	89	100	VIKBT80IL48S
DN 100	130	101.6	100	VIKBT100IL64I
DN 100	130	104	100	VIKBT100IL104M
DN 100	130	114.3	100	VIKBT100IL64S
DN 160	180	152.4	100	VIKBT160IL96I
DN 160	180	154	100	VIKBT160IL154M
DN 160	180	168.3	100	VIKBT160IL96S
DN 200	240	203.2	100	VIKBT200IL128I
DN 200	240	219.1	100	VIKBT200IL128S
DN 250	290	254	100	VIKBT250IL160I
DN 250	290	267	100	VIKBT250IL267M

Embout de réduction fixation par griffes

VIKRKK

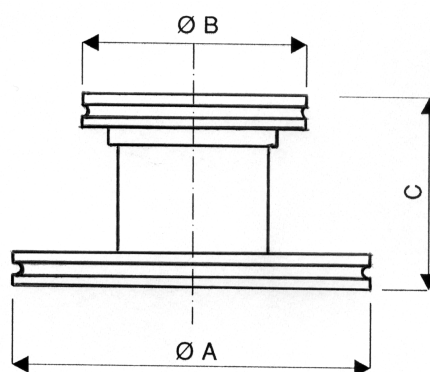

Ø nominal	A	B	C	Inox 316L	Inox 304
DN 100-63	130	95	50	VIKRKK100IL63	VIKRKK100I63
DN 100-80	130	110	50	VIKRKK100IL80	VIKRKK100I80
DN 160-100	180	130	50	VIKRKK160IL100	VIKRKK160I100
DN 160-63	180	110	50	VIKRKK160IL80	VIKRKK160I80
DN 160-63	180	95	50	VIKRKK160IL63	VIKRKK160I63
DN 200-160	240	180	80	VIKRKK200IL160	VIKRKK200I160
DN 200-100	240	130	80	VIKRKK200IL100	VIKRKK200I100

Embout coudé à fixation par griffes

VIKCE

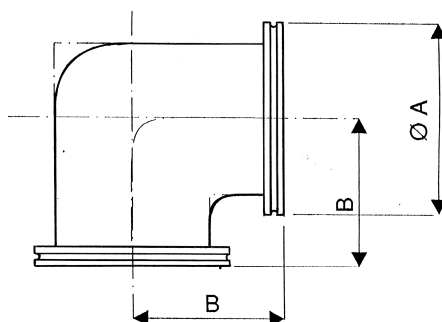

nominal	A	B	Inox 316L	Inox 304
DN 63	95	Peut varier selon le mode de fabrication	VIKCE63IL	VIKCE63I
DN 80	110		VIKCE80IL	VIKCE80I
DN 100	130		VIKCE100IL	VIKCE100I
DN 160	180		VIKCE160IL	VIKCE160I

Embout en té à fixation par griffes

VIKTE

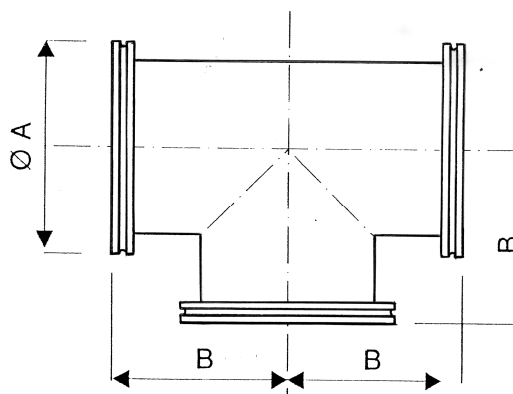

Ø nominal	A	B	Inox 316L	Inox 304
DN 63	95	Peut varier selon le mode de fabrication	VIKTE63IL	VIKTE63I
DN 80	110		VIKTE80IL	VIKTE80I
DN 100	130		VIKTE100IL	VIKTE100I
DN 160	180		VIKTE160IL	VIKTE160I

Embout en croix à fixation par griffes

VIKCR

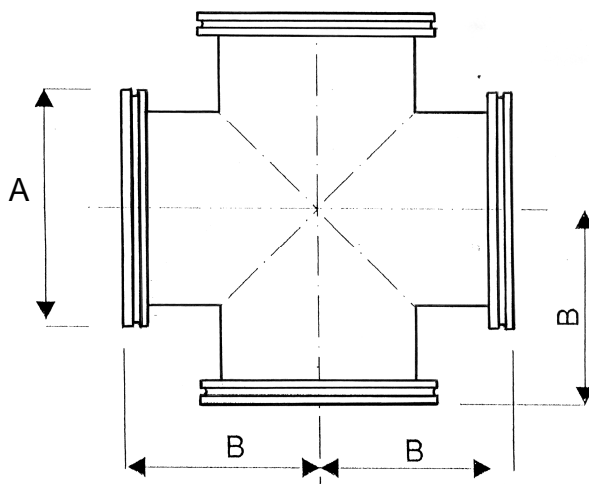

nominal	A	B	Inox 316L	Inox 304
DN 63	95	Peut varier selon le mode de fabrication	VIKCR63IL	VIKCR63I
DN 80	110		VIKCR80IL	VIKCR80I
DN 100	130		VIKCR100IL	VIKCR100I
DN 160	180		VIKCR160IL	VIKCR160I

Embout d'adaptation

VIKRKF

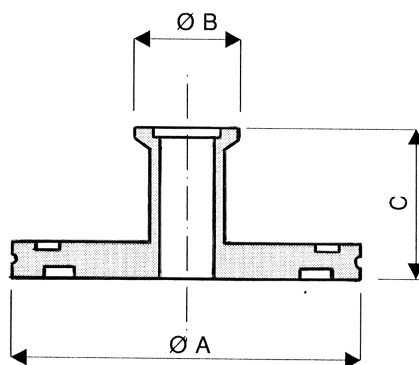

Ø nominal	A	B	C	Inox 316L
DN 63-40	95	55	50	VIKRKF63IL40
DN 63-50	95	75	50	VIKRKF63IL50
DN 80-40	110	55	50	VIKRKF80IL40
DN 80-50	110	75	50	VIKRKF80IL50
DN 100-40	130	55	50	VIKRKF100IL40
DN 100-50	130	75	50	VIKRKF100IL50
DN 160-50	180	75	50	VIKRKF160IL50

Autres DN sur demande

Flexible métallique avec bride a griffes

VIKFL

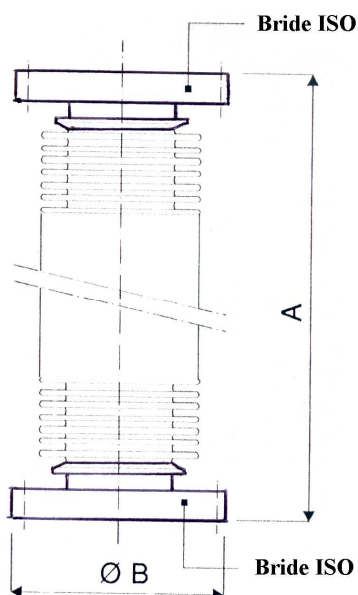

Ø nominal	A	B	Inox
DN 63	250	95	VIKFL63I250
	500	95	VIKFL63I500
	750	95	VIKFL63I750
	1000	95	VIKFL63I1000
DN 80	250	110	VIKFL80I250
	500	110	VIKFL80I500
	750	110	VIKFL80I750
	1000	110	VIKFL80I1000
DN 100	250	130	VIKFL100I250
	500	130	VIKFL100I500
	750	130	VIKFL100I750
	1000	130	VIKFL100I1000

Autres DN sur demande

Soufflet métallique avec bride a griffes

VIKSO

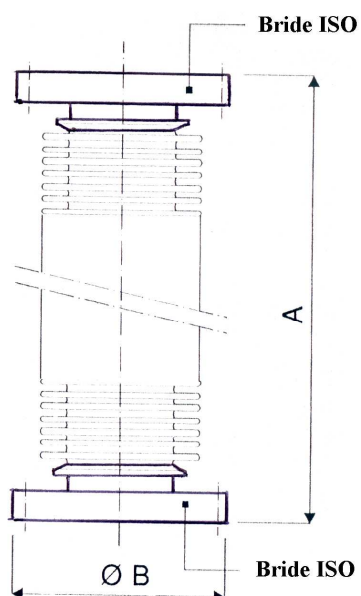

Ø nominal	longueur totale	Ø ext. brides	Longueur comprimée	Inox
DN 63	140	95	125	VIKSO63I140
DN 80	187	110	160	VIKSO80I187
DN 100	187	130	160	VIKSO100I187

Autres DN sur demande